

## Pressure Filters ■ Types SF / SF-TM / SF-SM / SFZ / SFA



SF

SF-TM

SF-SM

SFZ

SFA

### Product Description

STAUFF Pressure Filters are designed for manifold mounting or in-line hydraulic applications, with a maximum operating pressure up to 420 bar / 6000 PSI. Used together with STAUFF SE series Filter Elements, a high efficiency of contaminant removal is assured. The high dirt-hold capacity of the elements ensures long service life and, as a result, reduced maintenance costs.

### Technical Data

#### Construction

- SF: Designed for in-line assembly, with threaded mounting holes on top of head.
- SF-TM: Designed for manifold mounting, with mounting holes and fluid ports on top of head.
- SF-SM: Designed for manifold mounting, with mounting holes and fluid ports on side of head.
- SFZ: Designed for sandwich plate mounting
- SFA: Designed for in-line assembly, with threaded mounting holes on top of head.

#### Materials

- Filter head: Spheroidal Graphite Cast Iron  
Free Cutting Steel (only SF-TM014-070)  
SFA: Aluminium  
SFZ: Free Cutting Steel
- Filter bowl: Cold Drawn Steel  
SFA: Aluminium
- O-rings: NBR (Buna-N®)  
FPM (Viton®)  
EPDM (Ethylene-Propylene-Diene-Monomer-Rubber)
- Support ring: PTFE (Polytetrafluoroethylene)

#### Operating Pressure

- SF: max. 420 bar / 6000 PSI
- SF-TM: max. 315 bar / 4560 PSI
- SF-SM: max. 315 bar / 4560 PSI
- SFZ: max. 315 bar / 4560 PSI
- SFA: max. 160 bar / 2320 PSI

#### Temperature Range

- -10 °C ... +100 °C / +14 °F ... +212 °F

#### Filter Elements

- Specifications see page C41

#### Media Compatibility

- Mineral oils, other fluids on request

### Options and Accessories

#### Valve (not available for SFZ)

- Bypass valve: Allows unfiltered oil to bypass the contaminated element once the opening pressure has been reached, a differential pressure of  $6^{+0.5}$  bar /  $87^{+7.25}$  PSI  $\Delta p$  is the standard setting. Other settings available upon request.
- Reverse flow valve: Allows reverse flow through the filter head without backflushing the element.
- Non-return valve: Prevents draining of the delivery line during element change.
- Multi-function valve: Opening pressure  $6^{+0.5}$  bar /  $87^{+7.25}$  PSI  
Bypass, reverse flow capability and non-return valve combined in one valve.

#### Clogging Indicator

- Standard actuating pressure:  $5_{-0.5}$  bar /  $72.5_{-7.25}$  PSI  $\Delta p$   
Other actuating pressure settings are available upon request.
- Available indicators: Visual  
Electrical  
Visual-electrical (24 V DC, 110 V AC, 230 V AC versions)

## High Pressure Filters - Type SF

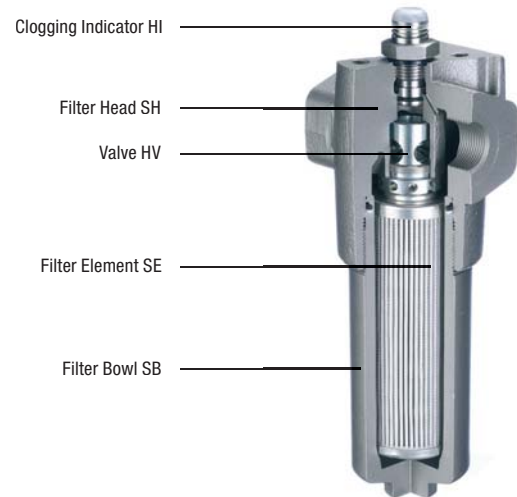
**Product Description**

STAUFF SF series High Pressure Filters are designed for in-line hydraulic applications, with a maximum operating pressure of 420 bar / 6000 PSI. Used together with STAUFF SE series Filter Elements, a high efficiency of contaminant removal is assured. The high dirt-hold capacity of the elements ensures long service life and, as a result, reduced maintenance costs.

**Technical Data**
**Construction**

- Designed for in-line assembly, with threaded mounting holes on top of head.

**Materials**

- Filter head: Spheroidal Graphite Cast Iron
- Filter bowl: Cold Drawn Steel
- O-rings: NBR (Buna-N®)  
FPM (Viton®)  
EPDM (Ethylene-Propylene-Diene-Monomer-Rubber)
- Support ring: PTFE (Polytetrafluoroethylene)

**Port Connections**

- BSP
- NPT
- SAE O-ring thread
- SAE Code 61 flange
- SAE Code 62 flange

Other port connections available on request.

**Operating Pressure**

- Max. 420 bar / 6000 PSI

**Burst Pressure**

- Min. 1260 bar / 18275 PSI

**Temperature Range**

- -10 °C ... +100 °C / +14 °F ... +212 °F

**Filter Elements**

- Specifications see page C22 / C41

**Media Compatibility**

- Mineral oils, other fluids on request

**Options and Accessories**
**Valve**

- Bypass valve: Allows unfiltered oil to bypass the contaminated element once the opening pressure has been reached, a differential pressure of  $6^{+0,5}$  bar /  $87^{+7,25}$  PSI  $\Delta p$  is the standard setting. Other settings available upon request.
- Reverse flow valve: Allows reverse flow through the filter head without backflushing the element.
- Non-return valve: Prevents draining of the delivery line during element change.
- Multi-function valve: Opening pressure  $6^{+0,5}$  bar /  $87^{+7,25}$  PSI  
Bypass, reverse flow capability and non-return valve combined in one valve.

**Clogging Indicator**

- Standard actuating pressure:  $5_{-0,5}$  bar /  $72.5_{-7,25}$  PSI  $\Delta p$   
Other actuating pressure settings are available upon request.
- Available indicators: Visual  
Electrical  
Visual-electrical (24 V DC, 110 V AC, 230 V AC versions)

High Pressure Filters - Type SF

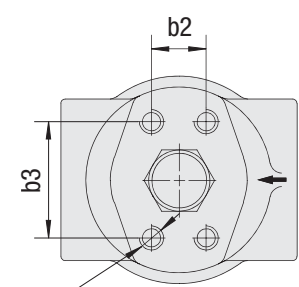
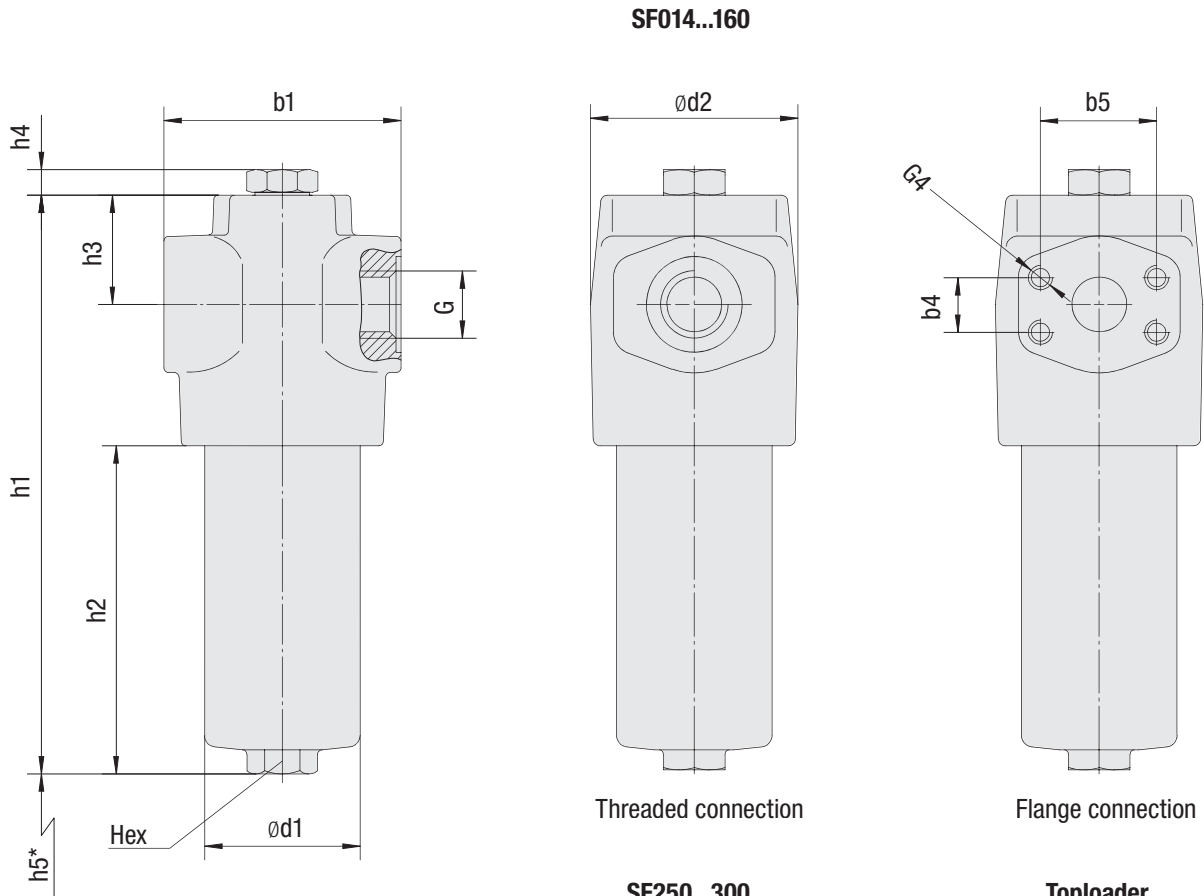

G2: for BSP threads, GM / FM / F1M flange  
 G3: for NPT, SAE O-ring thread, GU / FU / F1U flange

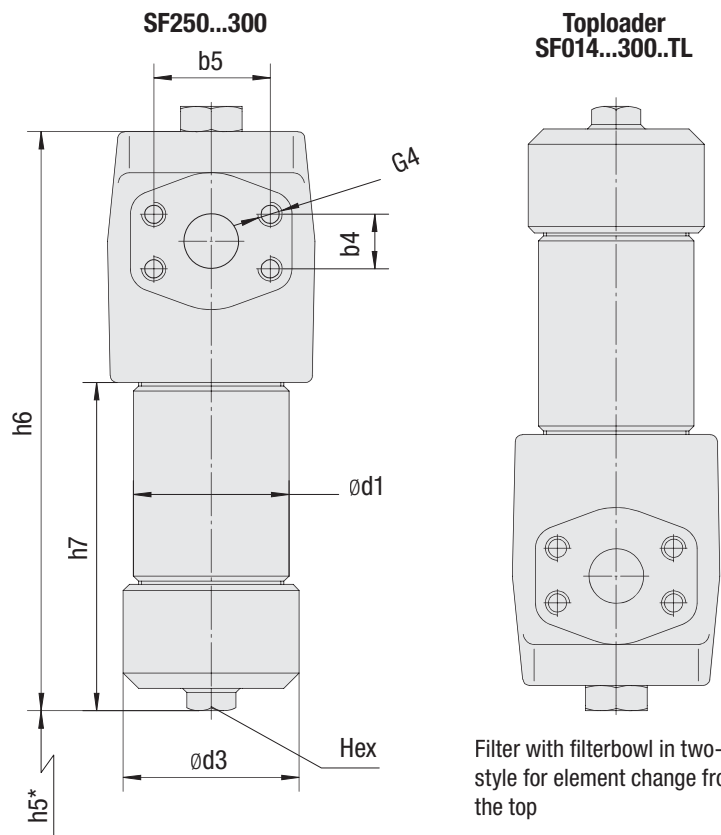

\* recommended space for element change

## High Pressure Filters - Type SF

Thread Connection G	Filter Size SF								
	014	030	045	070	125	090	160	250	300
BSP	3/4	3/4	1-1/4	1-1/4	1-1/4	1-1/2	1-1/2	1-1/2	1-1/2
NPT	3/4	3/4	1-1/4	1-1/4	1-1/4	1-1/2	1-1/2	1-1/2	1-1/2
SAE O-ring Thread	1-1/16-12	1-1/16-12	1-5/8-12	1-5/8-12	1-5/8-12	1-7/8-12	1-7/8-12	1-7/8-12	1-7/8-12
SAE Flange 6000 PSI	3/4	3/4	1-1/4	1-1/4	1-1/4	1-1/2	1-1/2	1-1/2	1-1/2
Weight (kg/lbs) incl. Elements with Filter Bowl in One-Part Style	5,3 11.7	6,2 13.7	10,3 22.7	12 26.5	16,3 35.9	27 59.9	35,5 78.3	- -	- -
Weight (kg/lbs) incl. Elements with Filter Bowl in Two-Part Style	5,9 13	6,9 15.2	12,2 26.9	13,7 30.2	20 44.1	32 70.5	39,3 86.5	49 108	57,3 126.3

Dimensions (mm/in)		Filter Size SF										
		014	030	045	070	125	090	160	250	300		
b1		104	104	128	128	128	178	178	178	178		
		4.10	4.10	5.04	5.04	5.04	7.01	7.01	7.01	7.01		
d2		91	91	116	116	116	159	159	159	159		
		3.58	3.58	4.57	4.57	4.57	6.26	6.26	6.26	6.26		
h3		48	48	49,5	49,5	49,5	72	72	72	72		
		1.89	1.89	1.95	1.95	1.95	2.84	2.84	2.84	2.84		
h4		12,5	12,5	12,5	12,5	12,5	12,5	12,5	12,5	12,5		
		.49	.49	.49	.49	.49	.49	.49	.49	.49		
with Filter Bowl in One-Part Style Type SF	d1		68	68	95	95	95	130	130	130	130	
			2.68	2.68	3.74	3.74	3.74	5.12	5.12	5.12	5.12	
	h1		188	254	239	298	483	323	494	-	-	
			7.40	10.00	9.41	11.73	19.11	12.72	19.45	-	-	
	h2		78	144	103	161	343	148	319	-	-	
			3.07	5.67	4.06	6.34	13.5	5.83	12.56	-	-	
	h5	Rec.*		100	170	140	200	380	190	360	-	-
				3.94	6.69	5.51	7.87	14.96	7.48	14.17	-	-
		Min.*		85	85	120	120	150	150	-	-	
			3.35	3.35	4.72	4.72	5.91	5.91	-	-	-	
	Hex		27	27	32	32	32	36	36	36	36	
			1.06	1.06	1.26	1.26	1.26	1.42	1.42	1.42	1.42	
with Filter Bowl in Two-Part Style Type SF...TL	d1		70	70	101,6	101,6	101,6	133	133	133	133	
			2.76	2.76	4	4	4	5.24	5.24	5.24	5.24	
	d3		84	84	115	115	115	155	155	155	155	
			3.31	3.31	4.53	4.53	4.53	6.10	6.10	6.10	6.10	
	h5		65	130	100	160	340	120	290	425	590	
			2.56	5.12	3.94	6.30	13.39	4.72	11.42	16.73	23.23	
	h6		190	256	241	300	485	329,5	500,5	656,5	821,5	
			7.48	10.08	9.49	11.81	19.10	12.97	19.71	25.85	32.34	
	h7		80	146	103	163	344	154,5	325,5	481,5	646,5	
			3.15	5.75	4.06	6.42	13.54	6.08	12.82	18.96	25.45	
Hex		27	27	32	32	32	36	36	36	36		
		1.06	1.06	1.26	1.26	1.26	1.42	1.42	1.42	1.42		

Reference: Rec.\*: Recommended | Min.\*: Minimum

Dimensions (mm/in)		Filter Size SF									
		014	030	045	070	125	090	160	250	300	
T	b2		23,8	23,8	31,6	31,6	31,6	36,7	36,7	36,7	36,7
			.94	.94	1.24	1.24	1.24	1.45	1.45	1.45	1.45
	b3		50,8	50,8	66,7	66,7	66,7	79,4	79,4	79,4	79,4
			2.00	2.00	2.63	2.63	2.63	3.13	3.13	3.13	3.13
Dimensions SAE Flange 6000 PSI	G2	M10 x 15			M14 x 20			M16 x 20			
	G3	3/8-16 UNC x .59			1/2-13 UNC x .79			5/8-11 UNC x .79			
	b4		23,8	23,8	31,6	31,6	31,6	36,7	36,7	36,7	36,7
			.94	.94	1.24	1.24	1.24	1.45	1.45	1.45	1.45
	b5		50,8	50,8	66,7	66,7	66,7	79,4	79,4	79,4	79,4
			2.00	2.00	2.63	2.63	2.63	3.13	3.13	3.13	3.13
G4	M10 x 15			M14 x 17			M16 x 20				
	3/8-16 UNC			1/2-13 UNC			5/8-11 UNC				

High Pressure Filter Housings / Complete Filters - Type SF

SF
014
...
...
B / 
 T
B / 
 B / 
 P
T
230 / 
 TL / 
 X

1
2
3
4
5
6
7
8
9
10
11
12
13

**1 Type**  
High Pressure Filter SF

**2 Group**

Flow	Size
60 l/min / 14 US GPM	<b>014</b>
110 l/min / 30 US GPM	<b>030</b>
160 l/min / 45 US GPM	<b>045</b>
240 l/min / 70 US GPM	<b>070</b>
330 l/min / 90 US GPM	<b>090</b>
475 l/min / 125 US GPM	<b>125</b>
660 l/min / 160 US GPM	<b>160</b>
990 l/min / 250 US GPM	<b>250</b>
1320 l/min / 300 US GPM	<b>300</b>

Note: Exact flow will depend on filter element selected.  
Consult technical data on pages C43 / C44.

**3 Filter Material**

Material	max. Δp*collapse	Micron ratings available	Code
Without filter element	-	-	...
Inorg. glass fibre	25 bar / 363 PSI	3, 5, 10, 20	<b>G</b>
Inorg. glass fibre	210 bar / 3045 PSI		<b>H</b>
Stainless fibre	210 bar / 3045 PSI		<b>A</b>
Stainless mesh	30 bar / 435 PSI	25, 50, 100, 200	B, S

Note: \* Collapse/burst resistance as per ISO 2941.  
Bold types identify preferred materials, other materials on request.

**4 Micron Rating**

3 µm	<b>03</b>
5 µm	<b>05</b>
10 µm	<b>10</b>
20 µm	<b>20</b>
25 µm	<b>25</b>
50 µm	<b>50</b>
100 µm	<b>100</b>
200 µm	<b>200</b>

Note: Other micron ratings on request.

**5 Sealing Material**

NBR (Buna-N®)	<b>B</b>
FPM (Viton®)	<b>V</b>
EPDM	<b>E</b>

Note: Other sealing materials on request.

**6 Connecting Flange**

Type T	<b>T</b>
--------	----------

**7 Connection Style**

Connection Style	Group										Thread Style	Code
	014	030	045	070	125	090	160	250	300			
BSP	3/4		1-1/4			1-1/2					metric	<b>B</b>
BSP	1		1-1/2			-					metric	B1
NPT	3/4		1-1/4			1-1/2					UNC	<b>N</b>
SAE O-ring Thread	1-1/16-12		1-5/8-12		1-7/8-12						UNC	<b>U</b>
SAE Flange 6000 PSI	3/4		1-1/4			1-1/2					metric	GM
SAE Flange 6000 PSI	3/4		1-1/4			1-1/2					UNC	<b>GU</b>
SAE Flange 3000 PSI	3/4		1-1/4			1-1/2					metric	FM
SAE Flange 3000 PSI	3/4		1-1/4			1-1/2					UNC	FU
SAE Flange 3000 PSI	1		-			2					metric	F1M
SAE Flange 3000 PSI	1		-			2					UNC	F1U

Note: Other port connections on request. Bold types identify preferred connection styles.

**8 Valve**

Without valve	<b>O</b>
Bypass valve	<b>B</b>
Reverse flow valve	<b>R</b>
Non-return valve	<b>N</b>
Multi-function valve	<b>M</b>

**9 Clogging Indicator**

Without clogging indicator	<b>O</b>
Visual, with automatic reset	<b>A</b>
Visual, with manual reset	<b>V</b>
Electrical	<b>E</b>
Visual-electrical	<b>P</b>

**10 Thermostop**

Without thermostop	<b>none</b>
With thermostop	<b>T</b>

**11 Voltage (only for Code P)**

24 V DC	<b>24</b>
110 V AC	<b>110</b>
230 V AC	<b>230</b>

**12 Style Filter Bowl**

With bowl in one-part style	<b>none</b>
Toploader, with bowl in two-part style	<b>TL</b>

Note: Group size SF250 and SF300 only available in TL-version.

**13 Design Code**

Only for information	<b>X</b>
----------------------	----------

Filter Elements - Type SE

SE - 
 014
G
10
B / 
 X

1
2
3
4
5
6

**1 Type**  
Filter Element Series SE

**2 Group**  
According to filter housing

**3 Filter Material**

Material	max. Δp*collapse	Micron ratings available	Code
Inorg. glass fibre	25 bar / 363 PSI	3, 5, 10, 20	<b>G</b>
Inorg. glass fibre	210 bar / 3045 PSI		<b>H</b>
Stainless fibre	210 bar / 3045 PSI		<b>A</b>
Stainless mesh	30 bar / 435 PSI	25, 50, 100, 200	B, S

**4 Micron Rating**

3 µm	<b>03</b>
5 µm	<b>05</b>
10 µm	<b>10</b>
20 µm	<b>20</b>
25 µm	<b>25</b>
50 µm	<b>50</b>
100 µm	<b>100</b>
200 µm	<b>200</b>

Note: Other micron ratings on request.  
\* Collapse/burst resistance as per ISO 2941.  
Bold types identify preferred materials, other materials on request.

**5 Sealing Material**

NBR (Buna-N®)	<b>B</b>
FPM (Viton®)	<b>V</b>
EPDM	<b>E</b>

Note: Other sealing materials on request.

**6 Design Code**

Only for information	<b>X</b>
----------------------	----------

## High Pressure Filters ■ Type SF-TM

**Product Description**

STAUFF SF-TM series High Pressure Filters are designed for manifold block mounting hydraulic applications, with a maximum operating pressure of 315 bar / 4560 PSI. Used together with STAUFF SE series Filter Elements, a high efficiency of contaminant removal is assured. The high dirt-hold capacity of the elements ensures long service life and, as a result, reduced maintenance costs.

**Technical Data**
**Construction**

- Designed for manifold mounting, with mounting holes and fluid ports on top of head.

**Materials**

- Filter head: SF-TM-014-070 Free Cutting Steel  
SF-TM-090-300 Spheroidal Graphite Cast Iron
- Filter bowl: Cold Drawn Steel
- O-rings: NBR (Buna-N®)  
FPM (Viton®)  
EPDM (Ethylene-Propylene-Diene-Monomer-Rubber)
- Support ring: PTFE (Polytetrafluoroethylene)

**Operating Pressure**

- Max. 315 bar / 4560 PSI

**Burst Pressure**

- Min. 945 bar / 13705 PSI

**Temperature Range**

- -10 °C ... +100 °C / +14 °F ... +212 °F

**Filter Elements**

- Specifications see page C26 / C41

**Media Compatibility**

- Mineral oils, other fluids on request

**Options and Accessories**
**Valve**

- Bypass valve: Allows unfiltered oil to bypass the contaminated element once the opening pressure has been reached, a differential pressure of  $6^{+0.5}$  bar /  $87^{+7.25}$  PSI  $\Delta p$  is the standard setting. Other settings available upon request.
- Reverse flow valve: Allows reverse flow through the filter head without backflushing the element.
- Non-return valve: Prevents draining of the delivery line during element change.
- Multi-function valve: Opening pressure  $6^{+0.5}$  bar /  $87^{+7.25}$  PSI  
Bypass, reverse flow capability and non-return valve combined in one valve.

**Clogging Indicator**

- Standard actuating pressure:  $5_{-0.5}$  bar /  $72.5_{-7.25}$  PSI  $\Delta p$   
Other actuating pressure settings are available upon request.
- Available indicators: Visual  
Electrical  
Visual-electrical (24 V DC, 110 V AC, 230 V AC versions)

High Pressure Filters - Type SF-TM

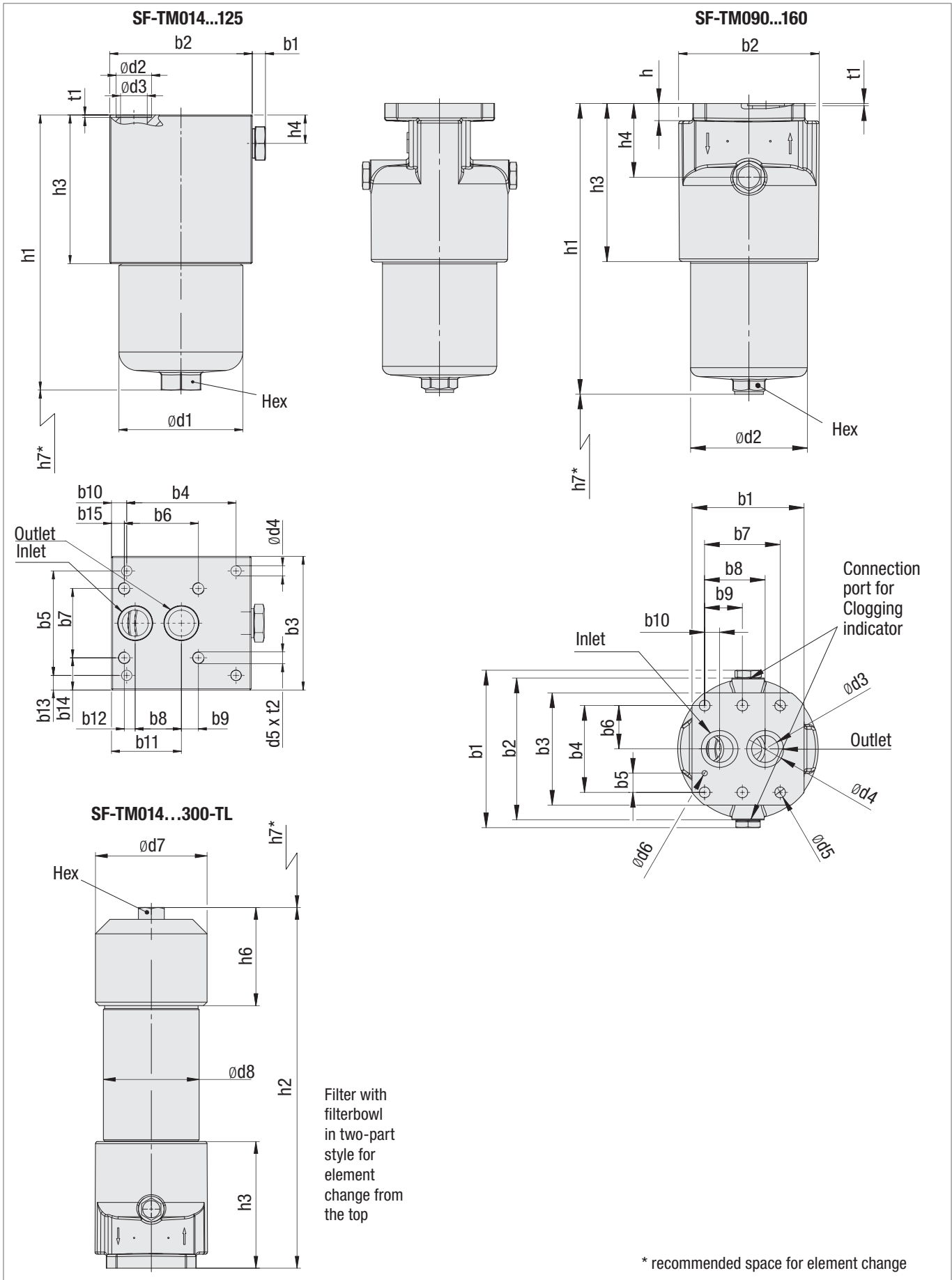

## High Pressure Filters - Type SF-TM

Dimensions (mm/in)			Filter Size SF - TM								
			014	030	045	070	125	090	160	250	300
b1			6	6	6	6	6	175,6	175,6	175,6	175,6
			.24	.24	.24	.24	.24	6.91	6.91	6.91	6.91
b2			104	104	115	115	115	158	158	158	158
			4.09	4.09	4.53	4.53	4.53	6.22	6.22	6.22	6.22
b3			80	80	110	110	110	125	125	125	125
			3.35	3.35	4.33	4.33	4.33	4.92	4.92	4.92	4.92
b4			89	89	90	90	90	96,8	96,8	96,8	96,8
			3.50	3.50	3.54	3.54	3.54	3.81	3.81	3.81	3.81
b5			31,8	31,8	86	86	86	21,4	21,4	21,4	21,4
			1.25	1.25	3.39	3.39	3.39	.84	.84	.84	.84
b6			-	-	61	61	61	48,4	48,4	48,4	48,4
			-	-	2.40	2.40	2.40	1.91	1.91	1.91	1.91
b7			-	-	57	57	57	84,1	84,1	84,1	84,1
			-	-	2.24	2.24	2.24	3.31	3.31	3.31	3.31
b8			31,6	31,6	38	38	38	67,4	67,4	67,4	67,4
			1.24	1.24	1.50	1.50	1.50	2.65	2.65	2.65	2.65
b9			-	-	14	14	14	42,05	42,05	42,05	42,05
			-	-	.55	.55	.55	1.66	1.66	1.66	1.66
b10			7,5	7,5	12,5	12,5	12,5	16,7	16,7	16,7	16,7
			.30	.30	.49	.49	.49	.66	.66	.66	.66
b11			55,9	55,9	57,5	57,5	57,5	-	-	-	-
			2.20	2.20	2.26	2.26	2.26	-	-	-	-
b12			-	-	9	9	9	-	-	-	-
			-	-	.35	.35	.35	-	-	-	-
b13			24,1	24,1	12	12	12	-	-	-	-
			.95	.95	.47	.47	.47	-	-	-	-
b14			-	-	26,5	26,5	26,5	-	-	-	-
			-	-	1.04	1.04	1.04	-	-	-	-
b15			-	-	10,5	10,5	10,5	-	-	-	-
			-	-	.41	.41	.41	-	-	-	-
d1			68,2	68,2	95,2	95,2	95,2	156	156	156	156
			2.69	2.69	3.75	3.75	3.75	6.14	6.14	6.14	6.14
d2			25,3	25,3	28,6	28,6	28,6	130,2	130,2	130,2	130,2
			1.00	1.00	1.13	1.13	1.13	5.13	5.13	5.13	5.13
d3			17,5	17,5	21,4	21,4	21,4	30	30	30	30
			.69	.69	.84	.84	.84	1.18	1.18	1.18	1.18
d4			8,5	8,5	9	9	9	41	41	41	41
			.33	.33	.35	.35	.35	1.61	1.61	1.61	1.61
d5			-	-	7/16-14 UNC	7/16-14 UNC	7/16-14 UNC	12	12	12	12
			-	-				.47	.47	.47	.47
d6			-	-	-	-	-	6	6	6	6
			-	-	-	-	-	.24	.24	.24	.24
d7			84	84	115	115	115	155	155	155	155
			3.31	3.31	4.53	4.53	4.53	6.10	6.10	6.10	6.10
d8			70	70	101,6	101,6	101,6	133	133	133	133
			2.76	2.76	4.00	4.00	4.00	5.24	5.24	5.24	5.24
h1			162	228	206	264	446	324	495	-	-
			6.38	8.97	8.11	10.39	17.56	12.76	19.49	-	-
h2			164	230	206	266	447	330,5	501,5	657,5	822,5
			6.46	9.06	8.11	10.47	17.60	13.01	19.74	25.89	32.38
h3			76	76	93	93	93	178	178	178	178
			2.99	2.99	3.66	3.66	3.66	7.01	7.01	7.01	7.01
h4			25	25	25	25	25	82	82	82	82
			.98	.98	.98	.98	.98	3.23	3.23	3.23	3.23
h5			-	-	-	-	-	19,1	19,1	19,1	19,1
			-	-	-	-	-	.75	.75	.75	.75
h6			64	64	82,5	82,5	82,5	136	136	136	136
			2.52	2.52	3.25	3.25	3.25	5.35	5.35	5.35	5.35
h7	One-Part Style	Rec.*	100	170	140	200	380	190	360	-	-
		Min.*	3.94	6.69	5.51	7.87	14.96	7.48	14.17	-	-
	Two-Part Style	85	85	120	120	120	150	150	-	-	
		3.35	3.35	4.72	4.72	4.72	5.91	5.91	-	-	
		65	130	100	160	340	120	290	425	590	
		2.56	5.12	3.94	6.30	13.39	4.72	11.42	16.73	23.23	
t1			2	2	2	2	2	3	3	3	3
			.08	.08	.08	.08	.08	.12	.12	.12	.12
t2			-	-	13	13	13	-	-	-	-
			-	-	.51	.51	.51	-	-	-	-
Hex			27	27	32	32	32	36	36	36	36
			1.06	1.06	1.26	1.26	1.26	1.42	1.42	1.42	1.42
Weight (kg/lbs)	One-Part Style		5,7	6,3	11	12,5	17	21,6	28,8	-	-
			12.5	13.9	24.2	27.8	37.8	48.0	64.0	-	-
	Two-Part Style		6,6	7,3	13,1	14,6	21	26,5	33,8	43,2	54,6
			14.7	16.2	29.1	32.4	46.7	58.9	75.1	96	121.3



High Pressure Filter Housings / Complete Filters - Type SF-TM

**SF-TM** **014** ... **B** / **B** / **B** / **P** **T** **230** / **TL** / **X**

1 2 3 4 5 6 7 8 9 10 11 12

**1 Type**  
High Pressure Filter Top Mounted **SF-TM**

**2 Group**

Flow	Size
60 l/min / 14 US GPM	<b>014</b>
110 l/min / 30 US GPM	<b>030</b>
160 l/min / 45 US GPM	<b>045</b>
240 l/min / 70 US GPM	<b>070</b>
330 l/min / 90 US GPM	<b>090</b>
475 l/min / 125 US GPM	<b>125</b>
660 l/min / 160 US GPM	<b>160</b>
990 l/min / 250 US GPM	<b>250</b>
1320 l/min / 300 US GPM	<b>300</b>

Note: Exact flow will depend on filter element selected.  
Consult technical data on pages C43 / C44.

**3 Filter Material**

Material	max. Δp*collapse	Micron ratings available	Code
Without filter element	-	-	...
Inorg. glass fibre	25 bar / 363 PSI	3, 5, 10, 20	<b>G</b>
Inorg. glass fibre	210 bar / 3045 PSI		<b>H</b>
Stainless fibre	210 bar / 3045 PSI		<b>A</b>
Stainless mesh	30 bar / 435 PSI	25, 50, 100, 200	<b>B, S</b>

Note: \* Collapse/burst resistance as per ISO 2941.  
Bold types identify preferred materials, other materials on request.

**4 Micron Rating**

3 µm	<b>03</b>
5 µm	<b>05</b>
10 µm	<b>10</b>
20 µm	<b>20</b>
25 µm	<b>25</b>
50 µm	<b>50</b>
100 µm	<b>100</b>
200 µm	<b>200</b>

Note: Other micron ratings on request.

**5 Sealing Material**

NBR (Buna-N®)	<b>B</b>
FPM (Viton®)	<b>V</b>
EPDM	<b>E</b>

Note: Other sealing materials on request.

**6 Connection Size**

Connection Size	Group									Code
	014	030	045	070	125	090	160	250	300	
Nominal Bore	1/2 (Ø17,5mm / Ø.69in)		1-1/4 (Ø21,4mm / Ø .85in)		1-1/2 (Ø30mm / Ø1.18in)					<b>B</b>

**7 Valve**

Without valve	<b>0</b>
Bypass valve	<b>B</b>
Reverse flow valve	<b>R</b>
Non-return valve	<b>N</b>
Multi-function valve	<b>M</b>

**8 Clogging Indicator**

Without clogging indicator	<b>0</b>
Visual, with automatic reset	<b>A</b>
Visual, with manual reset	<b>V</b>
Electrical	<b>E</b>
Visual-electrical	<b>P</b>

**9 Thermostop**

Without thermostop	<b>none</b>
With thermostop	<b>T</b>

**10 Voltage (only for Code P)**

24 V DC	<b>24</b>
110 V AC	<b>110</b>
230 V AC	<b>230</b>

**11 Style Filter Bowl**

With bowl in one-part style	<b>none</b>
Toploader, with bowl in two-part style	<b>TL</b>

Note: Group size SF-TM-250 and SF-TM-300 only available in TL-version.

**12 Design Code**

Only for information	<b>X</b>
----------------------	----------

Filter Elements - Type SE

**SE** - **014** **G** **10** **B** / **X**

1 2 3 4 5 6

**1 Type**  
Filter Element Series **SE**

**2 Group**  
According to filter housing

**3 Filter Material**

Material	max. Δp*collapse	Micron ratings available	Code
Inorg. glass fibre	25 bar / 363 PSI	3, 5, 10, 20	<b>G</b>
Inorg. glass fibre	210 bar / 3045 PSI		<b>H</b>
Stainless fibre	210 bar / 3045 PSI		<b>A</b>
Stainless mesh	30 bar / 435 PSI	25, 50, 100, 200	<b>B, S</b>

**4 Micron Rating**

3 µm	<b>03</b>
5 µm	<b>05</b>
10 µm	<b>10</b>
20 µm	<b>20</b>
25 µm	<b>25</b>
50 µm	<b>50</b>
100 µm	<b>100</b>
200 µm	<b>200</b>

Note: Other micron ratings on request.  
\* Collapse/burst resistance as per ISO 2941.  
Bold types identify preferred materials, other materials on request.

**5 Sealing Material**

NBR (Buna-N®)	<b>B</b>
FPM (Viton®)	<b>V</b>
EPDM	<b>E</b>

Note: Other sealing materials on request.

**6 Design Code**

Only for information	<b>X</b>
----------------------	----------

## High Pressure Filters ■ Type SF-SM

**Product Description**

STAUFF SF-SM series High Pressure Filters are designed for manifold block mounting hydraulic applications, with a maximum operating pressure of 315 bar / 4560 PSI. Used together with STAUFF SE series Filter Elements, a high efficiency of contaminant removal is assured. The high dirt-hold capacity of the elements ensures long service life and, as a result, reduced maintenance costs.

**Technical Data**
**Construction**

- Designed for manifold mounting, with mounting holes and fluid ports on side of head.

**Materials**

- Filter head: Spheroidal Graphite Cast Iron
- Filter bowl: Cold Drawn Steel
- O-rings: NBR (Buna-N®)  
FPM (Viton®)  
EPDM (Ethylene-Propylene-Diene-Monomer-Rubber)
- Support ring: PTFE (Polytetrafluoroethylene)

**Operating Pressure**

- Max. 315 bar / 4560 PSI

**Burst Pressure**

- Min. 945 bar / 13705 PSI

**Temperature Range**

- -10 °C ... +100 °C / +14 °F ... +212 °F

**Filter Elements**

- Specifications see page C30 / C41

**Media Compatibility**

- Mineral oils, other fluids on request

**Options and Accessories**
**Valve**

- Bypass valve: Allows unfiltered oil to bypass the contaminated element once the opening pressure has been reached, a differential pressure of  $6^{+0.5}$  bar /  $87^{+7.25}$  PSI  $\Delta p$  is the standard setting. Other settings available upon request.
- Reverse flow valve: Allows reverse flow through the filter head without backflushing the element.
- Non-return valve: Prevents draining of the delivery line during element change.
- Multi-function valve: Opening pressure  $6^{+0.5}$  bar /  $87^{+7.25}$  PSI  
Bypass, reverse flow capability and non-return valve combined in one valve.

**Clogging Indicator**

- Standard actuating pressure:  $5^{-0.5}$  bar /  $72.5^{-7.25}$  PSI  $\Delta p$   
Other actuating pressure settings are available upon request.
- Available indicators: Visual  
Electrical  
Visual-electrical (24 V DC, 110 V AC, 230 V AC versions)

High Pressure Filters - Type SF-SM

SF-SM014...125

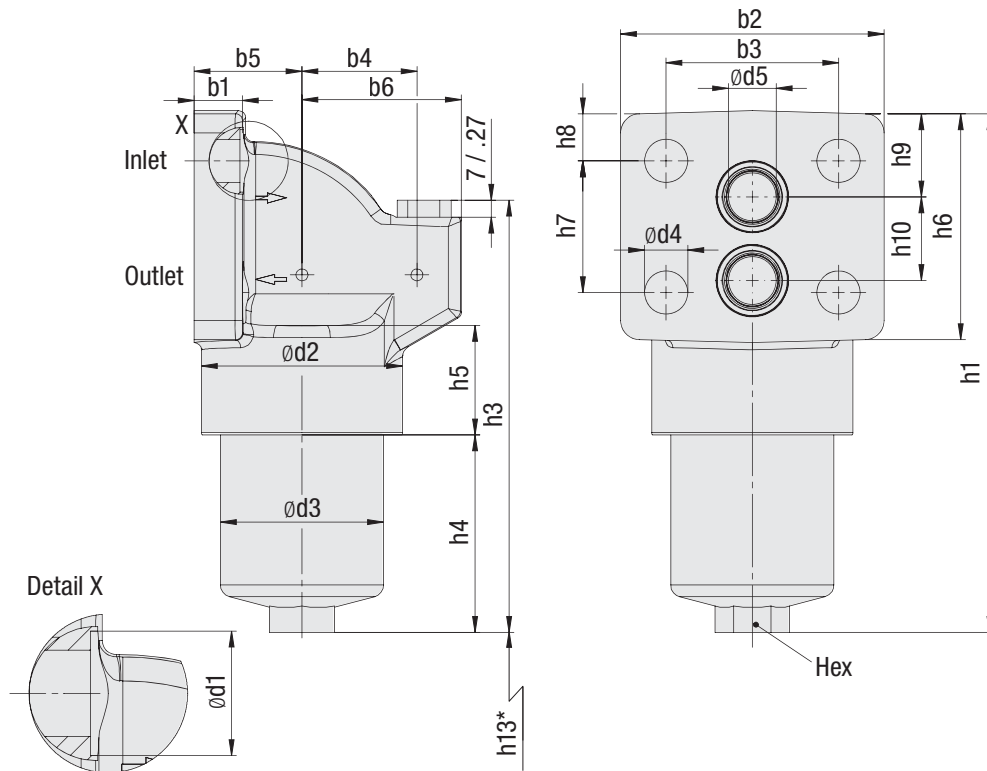

SF-SM090...160

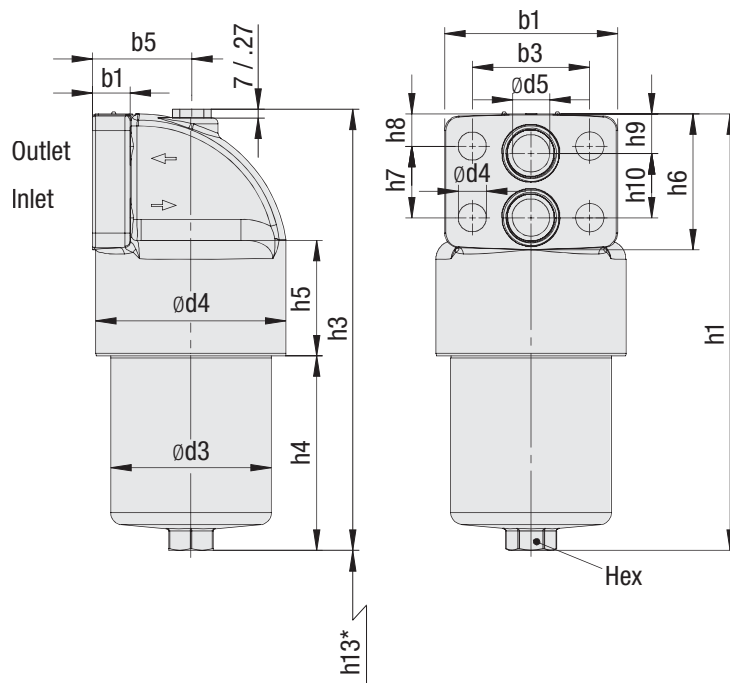

SF-SM014...300-TL

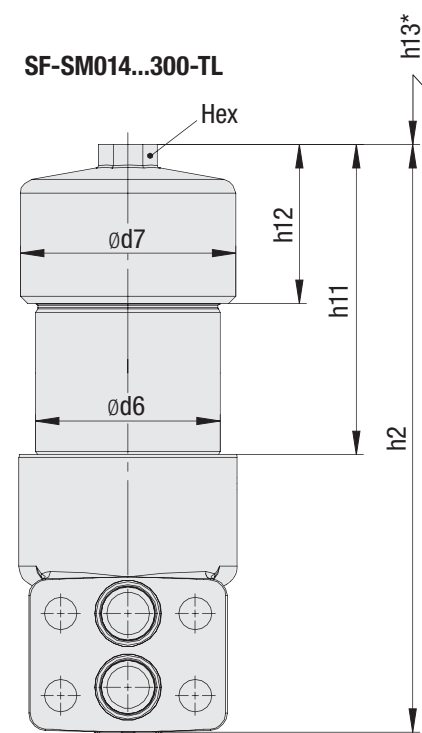

Filter with filterbowl in two-part style for element change from the top

\* recommended space for element change

## High Pressure Filters - Type SF-SM

Dimensions (mm/in)		Filter Size SF - SM												
		014	030	045	045 OAI	070	070 OAI	125	125 OAI	090	160	250	300	
b1		20	20	30	30	30	30	30	30	30	30	30	30	
		.79	.79	1.18	1.18	1.18	1.18	1.18	1.18	1.18	1.18	1.18	1.18	
b2		110	110	140	140	140	140	140	140	140	140	140	140	
		4.33	4.33	5.51	5.51	5.51	5.51	5.51	5.51	5.51	5.51	5.51	5.51	
b3		72	72	95	95	95	95	95	95	95	95	95	95	
		2.83	2.83	3.74	3.74	3.74	3.74	3.74	3.74	3.74	3.74	3.74	3.74	
b4		66	66	89	89	89	89	89	89	-	-	-	-	
		2.60	2.60	3.50	3.50	3.50	3.50	3.50	3.50	-	-	-	-	
b5		45	45	59	59	59	59	59	59	79,5	79,5	79,5	79,5	
		1.77	1.77	2.32	2.32	2.32	2.32	2.32	2.32	3.13	3.13	3.13	3.13	
b6		48	48	69	69	69	69	69	69	-	-	-	-	
		1.89	1.89	2.72	2.72	2.72	2.72	2.72	2.72	-	-	-	-	
d1		26	26	32	32	32	32	32	32	32	32	32	32	
		1.02	1.02	1.26	1.26	1.26	1.26	1.26	1.26	1.26	1.26	1.26	1.26	
d2		84	84	116	116	116	116	116	116	154	154	154	154	
		3.31	3.31	4.57	4.57	4.57	4.57	4.57	4.57	6.06	6.06	6.06	6.06	
d3		68	68	95	95	95	95	95	95	130	130	130	130	
		2.68	2.68	3.74	3.74	3.74	3.74	3.74	3.74	5.12	5.12	5.12	5.12	
d4		18	18	22	22	22	22	22	22	23	23	23	23	
		.71	.71	.87	.87	.87	.87	.87	.87	.91	.91	.91	.91	
d5		20	20	32	32	32	32	32	32	30	30	30	30	
		.79	.79	1.26	1.26	1.26	1.26	1.26	1.26	1.18	1.18	1.18	1.18	
d6		70	70	101,5	101,5	101,5	101,5	101,5	101,5	133	133	133	133	
		2.76	2.76	4.00	4.00	4.00	4.00	4.00	4.00	5.24	5.24	5.24	5.24	
d7		84	84	115	115	115	115	115	115	155	155	155	155	
		3.31	3.31	4.53	4.53	4.53	4.53	4.53	4.53	6.10	6.10	6.10	6.10	
h1		217	284	280	284	340	344	506	508	353	523	673	839	
		8.54	11.18	11.02	11.18	13.39	13.54	19.92	20.00	13.90	20.59	26.50	33.03	
h2		219	286	282	286	342	346	507	507	355	525	675	841	
		8.62	11.26	11.10	11.26	13.46	13.62	19.96	19.96	13.98	20.67	26.57	33.11	
h3		181	248	222	239	282	299	464	481	357	527	677	843	
		7.13	9.76	8.74	9.41	11.10	11.77	18.27	18.94	14.06	20.75	26.65	33.19	
h4		83	150	117	119	177	179	343	345	157	329	477	643	
		3.27	5.91	4.61	4.69	6.97	7.05	13.50	13.58	6.18	12.95	18.78	25.31	
h5		45,5	45,5	61	61	61	61	61	61	94	94	94	94	
		1.79	1.79	2.40	2.40	2.40	2.40	2.40	2.40	3.70	3.70	3.70	3.70	
h6		94	94	110	110	110	110	110	110	110	110	110	110	
		3.70	3.70	4.33	4.33	4.33	4.33	4.33	4.33	4.33	4.33	4.33	4.33	
h7		55	55	60	60	60	60	60	60	58	58	58	58	
		2.17	2.17	2.36	2.36	2.36	2.36	2.36	2.36	2.28	2.28	2.28	2.28	
h8		19,5	19,5	25	25	25	25	25	25	26	26	26	26	
		.77	.77	.98	.98	.98	.98	.98	.98	1.02	1.02	1.02	1.02	
h9		34,5	34,5	31	31	31	31	31	31	32	32	32	32	
		1.36	1.36	1.22	1.22	1.22	1.22	1.22	1.22	1.26	1.26	1.26	1.26	
h10		35	35	52	52	52	52	52	52	52	52	52	52	
		1.38	1.38	2.05	2.05	2.05	2.05	2.05	2.05	2.05	2.05	2.05	2.05	
h11		80	146	103	103	163	163	344	344	154,5	325,5	481,5	646,5	
		3.15	5.75	4.06	4.06	6.42	6.42	13.64	13.64	6.08	12.81	18.96	25.45	
h12		64	64	82,5	82,5	82,5	82,5	82,5	82,5	136	136	136	136	
		2.52	2.52	3.25	3.25	3.25	3.25	3.25	3.25	5.35	5.35	5.35	5.35	
h13	One-Part Style	Rec.*	100	170	140	140	200	200	380	380	190	360	-	-
		Min.*	3.94	6.69	5.51	5.51	7.87	7.87	14.96	14.96	7.48	14.17	-	-
	Two-Part Style		85	85	120	120	120	120	120	120	150	150	-	-
			3.35	3.35	4.72	4.72	4.72	4.72	4.72	4.72	5.91	5.91	-	-
O-ring		65	130	100	100	160	160	340	340	120	290	425	590	
		2.56	5.12	3.94	3.94	6.30	6.30	13.39	13.39	4.72	11.42	16.73	23.23	
Hex		24 x 3	24 x 3	40 x 3,5	40 x 3,5	40 x 3,5	40 x 3,5	40 x 3,5	40 x 3,5	40 x 3,5	40 x 3,5	40 x 3,5	40 x 3,5	
		.95 x .14	.95 x .14	1.57 x .14	1.57 x .14	1.57 x .14	1.57 x .14	1.57 x .14	1.57 x .14	1.57 x .14	1.57 x .14	1.57 x .14	1.57 x .14	
Weight (kg/lbs)	One-Part Style	5,2	6,1	9,6	10,7	11,6	12,7	15	17	22,9	30,9	-	-	
	Two-Part Style	11,4	13,4	21,1	23,5	25,5	27,9	33,0	37,4	50,4	68,0	-	-	
Weight (kg/lbs)		6,1	7,2	11,5	12,6	15,4	16,5	18,8	20,8	27,9	35,9	42,1	50,3	
		13,4	15,8	25,3	27,7	33,9	36,3	41,4	45,7	61,4	79,0	92,6	110,6	

Reference: Rec.\*: Recommended | Min.\*: Minimum

High Pressure Filter Housings / Complete Filters - Type SF-SM

SF-SM 014 ... B - B / P T 230 / TL / OAI / X

1 2 3 4 5 6 7 8 9 10 11 12

1 Type

High Pressure Filter Side Mounted **SF-SM**

2 Group

Flow	Size
60 l/min / 14 US GPM	<b>014</b>
110 l/min / 30 US GPM	<b>030</b>
160 l/min / 45 US GPM	<b>045</b>
240 l/min / 70 US GPM	<b>070</b>
330 l/min / 90 US GPM	<b>090</b>
475 l/min / 125 US GPM	<b>125</b>
660 l/min / 160 US GPM	<b>160</b>
990 l/min / 250 US GPM	<b>250</b>
1320 l/min / 300 US GPM	<b>300</b>

Note: Exact flow will depend on filter element selected. Consult technical data on pages C43 / C44.

3 Filter Material

Material	max. Δp*collapse	Micron ratings available	Code
Without filter element	-	-	...
Inorg. glass fibre	25 bar / 363 PSI	3, 5, 10, 20	<b>G</b>
Inorg. glass fibre	210 bar / 3045 PSI		<b>H</b>
Stainless fibre	210 bar / 3045 PSI		<b>A</b>
Stainless mesh	30 bar / 435 PSI	25, 50, 100, 200	<b>B, S</b>

Note: \* Collapse/burst resistance as per ISO 2941. Bold types identify preferred materials, other materials on request.

4 Micron Rating

3 μm	<b>03</b>
5 μm	<b>05</b>
10 μm	<b>10</b>
20 μm	<b>20</b>
25 μm	<b>25</b>
50 μm	<b>50</b>
100 μm	<b>100</b>
200 μm	<b>200</b>

Note: Other micron ratings on request.

5 Seal Material

NBR (Buna-N®)	<b>B</b>
FPM (Viton®)	<b>V</b>
EPDM	<b>E</b>

Note: Other sealing materials on request.

6 Valve

Without valve	<b>0</b>
Bypass valve	<b>B</b>
Reverse flow valve	<b>R</b>
Non-return valve	<b>N</b>
Multi-function valve	<b>M</b>

7 Clogging Indicator

Without clogging indicator	<b>0</b>
Visual, with automatic reset	<b>A</b>
Visual, with manual reset	<b>V</b>
Electrical	<b>E</b>
Visual-electrical	<b>P</b>

8 Thermostop

Without thermostop	<b>none</b>
With thermostop	<b>T</b>

9 Voltage (only for Code P)

24 V DC	<b>24</b>
110 V AC	<b>110</b>
230 V AC	<b>230</b>

10 Style Filterbowl

With bowl in one-part style	<b>none</b>
Toploader, with bowl in two-part style	<b>TL</b>

Note: Group size SF-SM-250 and SF-SM-300 only available in TL-version.

11 Port Connection Location

Inlet above outlet	<b>IAO</b>
Outlet above inlet	<b>OAI</b>

Note: IAO only for SF-SM-014/030/045/070/125  
OAI not available for SF-SM-014/030

12 Design Code

Only for information	<b>X</b>
----------------------	----------

Filter Elements - Type SE

SE - 014 G 10 B / X

1 2 3 4 5 6

1 Type

Filter Element Series **SE**

2 Group

According to filter housing

3 Filter Material

Material	max. Δp*collapse	Micron ratings available	Code
Inorg. glass fibre	25 bar / 363 PSI	3, 5, 10, 20	<b>G</b>
Inorg. glass fibre	210 bar / 3045 PSI		<b>H</b>
Stainless fibre	210 bar / 3045 PSI		<b>A</b>
Stainless mesh	30 bar / 435 PSI	25, 50, 100, 200	<b>B, S</b>

4 Micron Rating

3 μm	<b>03</b>
5 μm	<b>05</b>
10 μm	<b>10</b>
20 μm	<b>20</b>
25 μm	<b>25</b>
50 μm	<b>50</b>
100 μm	<b>100</b>
200 μm	<b>200</b>

Note: Other micron ratings on request.  
\* Collapse/burst resistance as per ISO 2941. Bold types identify preferred materials, other materials on request.

5 Sealing Material

NBR (Buna-N®)	<b>B</b>
FPM (Viton®)	<b>V</b>
EPDM	<b>E</b>

Note: Other sealing materials on request.

6 Design Code

Only for information	<b>X</b>
----------------------	----------

## High Pressure Filters ▪ Type SFZ

**Product Description**

STAUFF SFZ series High Pressure Filters are designed for sandwich plate mounting in manifold block mounting hydraulic applications, with a maximum operating pressure of 315 bar / 4560 PSI. Used together with STAUFF SE series Filter Elements, a high efficiency of contaminant removal is assured. The high dirt-hold capacity of the elements ensures long service life and, as a result, reduced maintenance costs.

**Technical Data**
**Construction**

- Designed for sandwich plate mounting

**Materials**

- Filter head: Free Cutting Steel
- Filter bowl: Cold Drawn Steel
- O-rings: NBR (Buna-N®)  
FPM (Viton®)  
EPDM (Ethylene-Propylene-Diene-Monomer-Rubber)
- Support ring (bowl): PTFE (Polytetrafluoroethylene)

**Connecting Port**

- According to ISO 4401-03-02-0-05 NG6  
(Ref.: NFPA/ANSI D03)

**Operating Pressure**

- Max. 315 bar / 4560 PSI

**Burst Pressure**

- Min. 945 bar / 13705 PSI

**Temperature Range**

- -10 °C ... +100 °C / +14 °F ... +212 °F

**Filter Elements**

- Specifications see page C34 / C41

**Media Compatibility**

- Mineral oils, other fluids on request

**O-Ring**

- 9x1,7 (included in delivery)

**Options and Accessories**
**Clogging Indicator**

- Standard actuating pressure: 5<sub>-0,5</sub> bar / 72.5<sub>-7,25</sub> PSI Δp  
8<sub>-0,5</sub> bar / 116<sub>-7,25</sub> PSI Δp  
Other actuating pressure settings are available upon request.
- Available indicators: Visual  
Electrical  
Visual-electrical (24 V DC, 110 V AC, 230 V AC versions)

High Pressure Filters - Type SFZ

Version - right

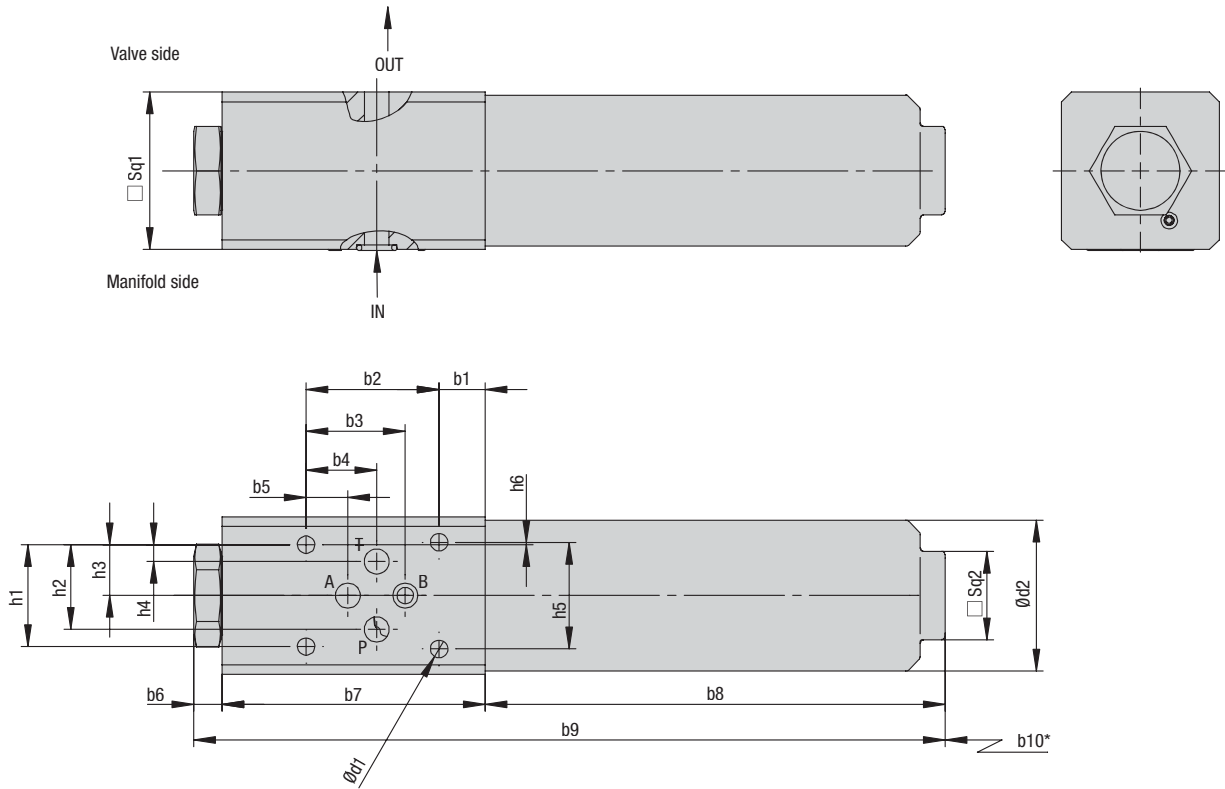

Version - left

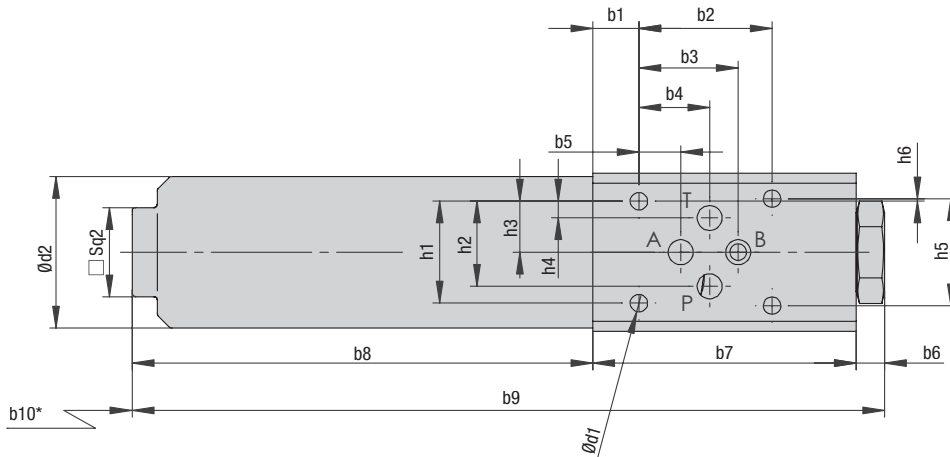

Symbol for hydraulic systems  
SFZ008

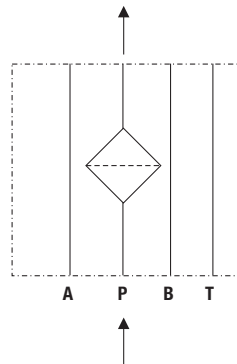

\* recommended space for element change

## High Pressure Filters ▪ Type SFZ

Dimensions (mm/in)	Filter Size SFZ
	SFZ008
b1	14
	.55
b2	40,5
	1.59
b3	30,2
	1.19
b4	21,5
	.85
b5	12,7
	.50
b6	9
	.35
b7	80
	3.15
b8	140
	5.51
b9	229
	9.02
b10	50
	1.97
d1	5,3
	.21
d2	46
	1.81
h1	31
	1.22
h2	25,8
	1.02
h3	15,5
	.61
h4	5,1
	.20
h5	32,5
	1.28
h6	0,75
	.03
Sq1	48
	1.89
Sq2	27
	1.06



High Pressure Filter Housings / Complete Filters - Type SFZ

**SFZ** **008** ... **B** / **B** / **P** **T** **230** - **5,0** / **R** / **X**

1 2 3 4 5 6 7 8 9 10 11 12

**1 Type**

High Pressure Filter for sandwich plate mounting **SFZ**

**2 Group**

Flow **Size**  
30 l/min / 8 US GPM **008**

Note: Exact flow will depend on filter element selected.

**3 Filter Material**

Please note that the filter element is not protected by an internal bypass. Please be sure that the hydraulic systems is designed with the sufficient means to protect the element.

Material	max. Δp*collapse	Micron ratings available	Code
Without filter element	-	-	...
Inorg. glass fibre	25 bar / 363 PSI	3, 5, 10, 20	<b>G</b>
Inorg. glass fibre	210 bar / 3045 PSI		<b>H</b>
Stainless fibre	210 bar / 3045 PSI		<b>M</b>
Stainless mesh	30 bar / 435 PSI	25, 50, 100, 200	S

Note: \* Collapse/burst resistance as per ISO 2941.  
Bold types identify preferred materials, other materials on request.

**4 Micron Rating**

3 µm	<b>03</b>
5 µm	<b>05</b>
10 µm	<b>10</b>
20 µm	<b>20</b>
25 µm	<b>25</b>
50 µm	<b>50</b>
100 µm	<b>100</b>
200 µm	<b>200</b>

Note: Other micron ratings on request.

**5 Sealing Material**

NBR (Buna-N®)	<b>B</b>
FPM (Viton®)	<b>V</b>
EPDM	<b>E</b>

Note: Other sealing materials on request.

**6 Connection Size**

Connection Size	Group	Code
	008	
Nominal Bore	NG6* (Ref.: D03)	<b>B</b>

\* ISO 4401-03-02-0-05

**7 Clogging Indicator**

Without clogging indicator	<b>0</b>
Visual, with automatic reset	<b>A</b>
Visual, with manual reset	<b>V</b>
Electrical	<b>E</b>
Visual-electrical	<b>P</b>

**8 Thermostop**

Without thermostop	<b>none</b>
With thermostop	<b>T</b>

**9 Voltage (only for Code P)**

24 V DC	<b>024</b>
110 V AC	<b>110</b>
230 V AC	<b>230</b>

**10 Actuating Pressure Clogging Indicator**

5,0 bar / 72,5 PSI	<b>5,0</b>
8,0 bar / 116 PSI	<b>8,0</b>

**11 Design**

Version right	<b>R</b>
Version left	<b>L</b>

**12 Design Code**

Only for information	<b>X</b>
----------------------	----------

Filter Elements - Type SE

**SE** - **008** **E** **10** **B** / **X**

1 2 3 4 5 6

**1 Type**

Filter Element Series **SE**

**2 Group**

According to filter housing

**3 Filter Material**

Please note that the filter element is not protected by an internal bypass. Please be sure that the hydraulic systems is designed with the sufficient means to protect the element.

Material	max. Δp*collapse	Micron ratings available	Code
Inorg. glass fibre	25 bar / 363 PSI	3, 5, 10, 20	<b>G</b>
Inorg. glass fibre	210 bar / 3045 PSI		<b>H</b>
Stainless fibre	210 bar / 3045 PSI		<b>M</b>
Stainless mesh	30 bar / 435 PSI	25, 50, 100, 200	S

\* Collapse/burst resistance as per ISO 2941.  
Bold types identify preferred materials, other materials on request.

**4 Micron Rating**

3 µm	<b>03</b>
5 µm	<b>05</b>
10 µm	<b>10</b>
20 µm	<b>20</b>
25 µm	<b>25</b>
50 µm	<b>50</b>
100 µm	<b>100</b>
200 µm	<b>200</b>

Note: Other micron ratings on request.

**5 Sealing Material**

NBR (Buna-N®)	<b>B</b>
FPM (Viton®)	<b>V</b>
EPDM	<b>E</b>

Note: Other sealing materials on request.

**6 Design Code**

Only for information	<b>X</b>
----------------------	----------

## Medium Pressure Filters - Type SFA

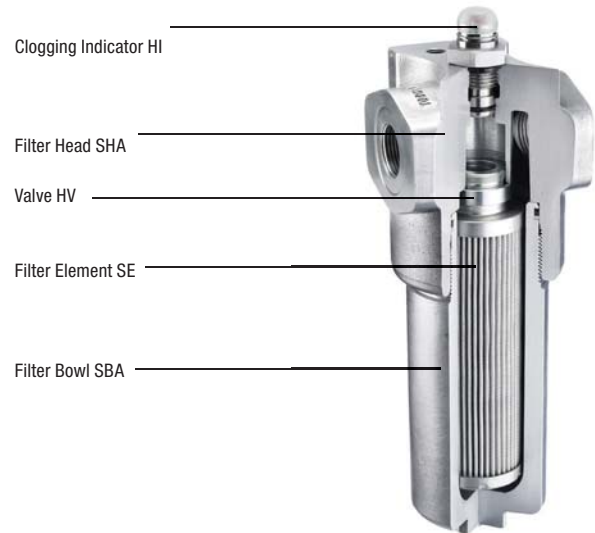
**Product Description**

STAUFF SFA series Medium Pressure Filters are designed for in-line hydraulic applications with a maximum operating pressure of 160 bar / 2320 PSI. Used together with STAUFF SE series Filter Elements, a high efficiency of contamination removal is assured. The dirt-hold capacity of the elements ensures long service life, and as a result, reduced maintenance costs.

**Technical Data**
**Construction**

- Designed for in-line assembly, with threaded mounting holes on top of head.

**Materials**

- Filter head: Cast Aluminum
- Filter bowl: Aluminium
- O-rings: NBR (Buna-N®)  
FPM (Viton®)  
EPDM (Ethylene-Propylene-Diene-Monomer-Rubber)
- Support ring: PTFE (Polytetrafluoroethylene)

**Port Connections**

- BSP
- NPT
- SAE O-ring thread
- SAE Code 61 Flange

**Operating Pressure**

- SFA014/030: Max. 160 bar / 2320 PSI  
Max. 190 bar / 2755 PSI (according to ANSI T2.6.1. R2-2001)
- SFA045/070: Max. 150 bar / 2175 PSI  
Max. 171 bar / 2480 PSI (according to ANSI T2.6.1. R2-2001)

**Burst Pressure**

- Min. 480 bar / 6960 PSI

**Temperature Range**

- -10 °C ... +100 °C / +14 °F ... +212 °F

**Filter Elements**

- Specifications see page C38 / C41

**Media Compatibility**

- Mineral oils, other fluids on request

**Options and Accessories**
**Valve**

- Bypass valve: Allows unfiltered oil to bypass the contaminated element once the opening pressure has been reached, a differential pressure of  $6^{+0.5}$  bar /  $87^{+7.25}$  PSI  $\Delta p$  is the standard setting. Other settings available upon request.
- Reverse flow valve: Allows reverse flow through the filter head without backflushing the element.
- Non-return valve: Prevents draining of the delivery line during element change.
- Multi-function valve: Opening pressure  $6^{+0.5}$  bar /  $87^{+7.25}$  PSI  
Bypass, reverse flow capability and non-return valve combined in one valve.

**Clogging Indicator**

- Standard actuating pressure:  $5_{-0.5}$  bar /  $72.5_{-7.25}$  PSI  $\Delta p$   
Other actuating pressure settings are available upon request.
- Available indicators: Visual  
Electrical  
Visual-electrical (24 V DC, 110 V AC, 230 V AC versions)

Medium Pressure Filters - Type SFA

SFA014...070

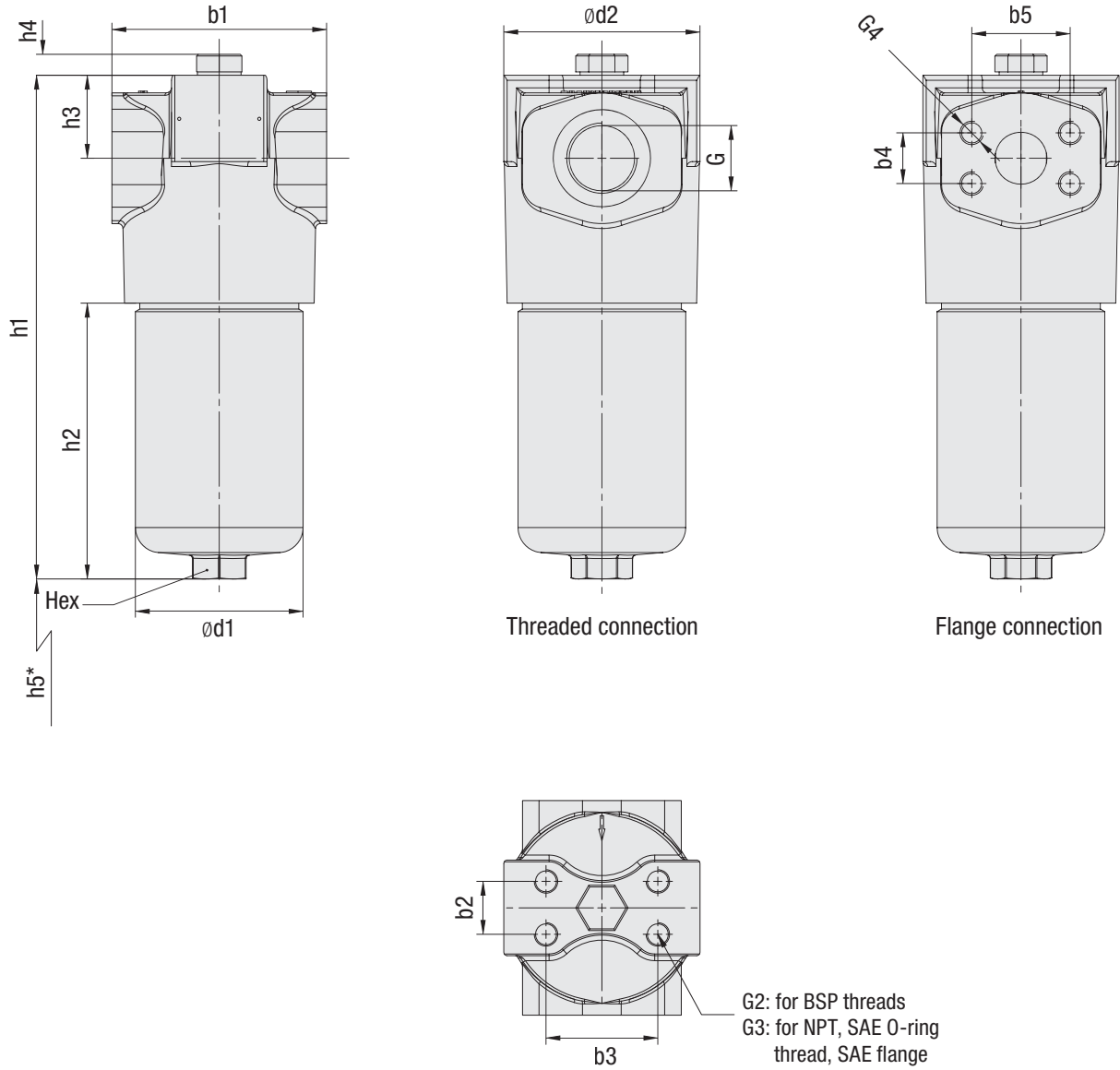

\* recommended space for element change

## Medium Pressure Filters - Type SFA

Thread Connection G	Filter Size SFA			
	014	030	045	070
BSP	3/4	3/4	1-1/4	1-1/4
NPT	3/4	3/4	1-1/4	1-1/4
SAE O-ring Thread	1-1/6-12	1-1/6-12	1-5/8-12	1-5/8-12
SAE Flange 3000 PSI	3/4	3/4	3/4	3/4
Weight (kg/lbs)	2,1	2,54	4,6	5,3
	4,7	5,6	10,2	11,8

Dimensions (mm/in)	Filter Size SFA			
	014	030	045	070
b1	92	92	128	128
	3.62	3.62	5.04	5.04
b2	23,8	23,8	31,6	31,6
	.94	.94	1.24	1.24
b3	50,8	50,8	66,7	66,7
	2.00	2.00	2.63	2.63
d1	72	72	100	100
	2.83	2.83	3.93	3.93
d2	86	86	117	117
	3.39	3.39	4.61	4.61
h1	187,5	255	241,5	301
	7.38	10.04	9.51	11.85
h2	78	145,5	105	164,5
	3.07	5.73	4.13	6.46
h3	40	40	49,5	49,5
	1.58	1.58	1.95	1.95
h4	12,5	12,5	12,5	12,5
	.49	.49	.49	.49
h5	100	170	140	200
	3.94	6.69	5.51	7.87
	85	85	120	120
	3.35	3.35	4.72	4.72
Hex	27	27	32	32
	1.05	1.05	1.25	1.25
G2	M10 x 15	M10 x 15	M14 x 20	M14 x 20
G3	3/8-16 UNC x .59	3/8-16 UNC x .59	1/2-13 UNC x .59	1/2-13 UNC x .59

Reference: Rec.\*: Recommended | Min.\*: Minimum

Dimensions SAE Flange 3000 PSI (mm/in)	Filter Size SFA			
	014	030	045	070
b4	22,2	22,2	47,6	47,6
	.87	.87	1.87	1.87
b5	30,2	30,2	58,7	58,7
	1.19	1.19	2.32	2.32
G4	M10 x 15 or 3/8-16 UNC	M10 x 15 or 3/8-16 UNC	M14 x 17 or 7/8-14 UNC	M14 x 17 or 7/8-14 UNC

Medium Pressure Filter Housings / Complete Filters - Type SFA

SFA
014
...
...
V / 
 T
B / 
 B / 
 P
T
230 / 
 X

1
2
3
4
5
6
7
8
9
10
11
12

**1 Type**  
Medium Pressure Filter **SFA**

**2 Group**

Flow	Size
60 l/min / 14 US GPM	<b>014</b>
110 l/min / 30 US GPM	<b>030</b>
160 l/min / 45 US GPM	<b>045</b>
240 l/min / 70 US GPM	<b>070</b>

Note: Exact flow will depend on filter element selected.  
Consult technical data on pages C43 / C44.

**3 Filter Material**

Material	max. Δp*collapse	Micron ratings available	Code
Without filter element	-	-	...
Inorg. glass fibre	25 bar / 363 PSI	3, 5, 10, 20	<b>G</b>
Inorg. glass fibre	210 bar / 3045 PSI		<b>H</b>
Stainless fibre	210 bar / 3045 PSI		<b>A</b>
Stainless mesh	30 bar / 435 PSI	25, 50, 100, 200	<b>B, S</b>

Note: \* Collapse/burst resistance as per ISO 2941.  
Bold types identify preferred materials, other materials on request.

**4 Micron Rating**

3 µm	<b>03</b>
5 µm	<b>05</b>
10 µm	<b>10</b>
20 µm	<b>20</b>
25 µm	<b>25</b>
50 µm	<b>50</b>
100 µm	<b>100</b>
200 µm	<b>200</b>

Note: Other micron ratings on request.

**5 Sealing Material**

NBR (Buna-N®)	<b>B</b>
FPM (Viton®)	<b>V</b>
EPDM	<b>E</b>

Note: Other sealing materials on request.

**6 Connection Flange**  
Type **T**

**7 Connection Style**

Connection Style	Group				Thread Style	Code
	014	030	045	070		
BSP	3/4		1-1/4		metric	<b>B</b>
BSP	1		1-1/2		metric	B1
NPT	3/4		1-1/4		UNC	N
SAE O-ring Thread	1-1/16-12		1-5/8-12		UNC	U
SAE Flange 3000 PSI	3/4		1-1/4		metric	FM
SAE Flange 3000 PSI	3/4		1-1/4		UNC	FU
SAE Flange 3000 PSI	1		-		metric	F1M
SAE Flange 3000 PSI	1		-		UNC	F1U

Note: Other port connections on request. Bold types identify preferred connection styles.

**8 Valve**

Without valve	<b>0</b>
Bypass valve	<b>B</b>
Reverse flow valve	<b>R</b>
Non-return valve	<b>N</b>
Multi-function valve	<b>M</b>

**9 Clogging Indicator**

Without clogging indicator	<b>0</b>
Visual, with automatic reset	<b>A</b>
Visual, with manual reset	<b>V</b>
Electrical	<b>E</b>
Visual-electrical	<b>P</b>

**10 Thermostop**

Without thermostop	<b>none</b>
With thermostop	<b>T</b>

**11 Voltage (only for Code P)**

24 V DC	<b>24</b>
110 V AC	<b>110</b>
230 V AC	<b>230</b>

**12 Design Code**  
Only for information **X**

Filter Elements - Type SE

SE - 
 014
G
10
B / 
 X

1
2
3
4
5
6

**1 Type**  
Filter Element Series **SE**

**2 Group**  
According to filter housing

**3 Filter Material**

Material	max. Δp*collapse	Micron ratings available	Code
Inorg. glass fibre	25 bar / 363 PSI	3, 5, 10, 20	<b>G</b>
Inorg. glass fibre	210 bar / 3045 PSI		<b>H</b>
Stainless fibre	210 bar / 3045 PSI		<b>A</b>
Stainless mesh	30 bar / 435 PSI	25, 50, 100, 200	<b>B, S</b>

**4 Micron Rating**

3 µm	<b>03</b>
5 µm	<b>05</b>
10 µm	<b>10</b>
20 µm	<b>20</b>
25 µm	<b>25</b>
50 µm	<b>50</b>
100 µm	<b>100</b>
200 µm	<b>200</b>

Note: Other micron ratings on request.  
\* Collapse/burst resistance as per ISO 2941.  
Bold types identify preferred materials, other materials on request.

**5 Sealing Material**

NBR (Buna-N®)	<b>B</b>
FPM (Viton®)	<b>V</b>
EPDM	<b>E</b>

Note: Other sealing materials on request.

**6 Design Code**  
Only for information **X**

**Product Description**

The optional valves are fitted as an insert in the filter head and incorporate the spigot on which the element seals. The valve is selected to suit the filter application.

<p><b>HV-O</b>      <b>Non-bypass standard insert</b> without any valve function. Element collapse rating should be higher than system pressure</p>	<p><b>HV-N</b>      <b>Non-return valve</b> This valve prevents the oil in the delivery line from draining out while the filter is being serviced. Because there is no bypass, the element collapse rating should be higher than system pressure.</p>
<p><b>HV-B</b>      <b>Bypass valve</b> which allows oil to bypass the element when the differential pressure across the element reaches <math>6^{+0.5}</math> bar / <math>87^{+7.25}</math> PSI. (Other pressure settings available on request). The opening pressure should be higher than the <math>\Delta p</math> setting of an optional clogging indicator. Low collapse 30 bar / 435 PSI <math>\Delta p</math> elements are normally used with this valve.</p>	<p><b>HV-M</b>      <b>Multi-function valve</b> This valve combines the bypass, the reverse flow and the non-return functions in one unit. The by-pass opening pressure is <math>6^{+0.5}</math> bar / <math>87^{+7.25}</math> PSI <math>\Delta p</math> with other opening pressures available on request. The opening pressure should be higher than the <math>\Delta p</math> setting of an optional clogging indicator. Low collapse 30 bar / 435 PSI <math>\Delta p</math> elements are normally used with this valve.</p>
<p><b>HV-R</b>      <b>Reverse flow valve</b> is used in systems where there is flow in reverse through the filter. It allows reverse flow without backflushing the element but does not filter in the reverse direction. Element collapse rating should be higher than the system pressure.</p>	

**Order Code**

**HV - M 014 / 030 / X**

1

2

3

4

**1 Type**

Valve for Pressure Filters **HV**

**2 Valve Type**

Non-bypass standard insert without any valve	<b>O</b>
Bypass valve	<b>B</b>
Reverse flow valve	<b>R</b>
Non-return valve	<b>N</b>
Multi-function valve	<b>M</b>

**3 Filter Group**

For filter size 014/030	<b>014/030</b>
For filter size 045/070/125	<b>045/070</b>
For filter size 090/160/250/300	<b>090/160</b>

**4 Design Code**

Only for information **X**

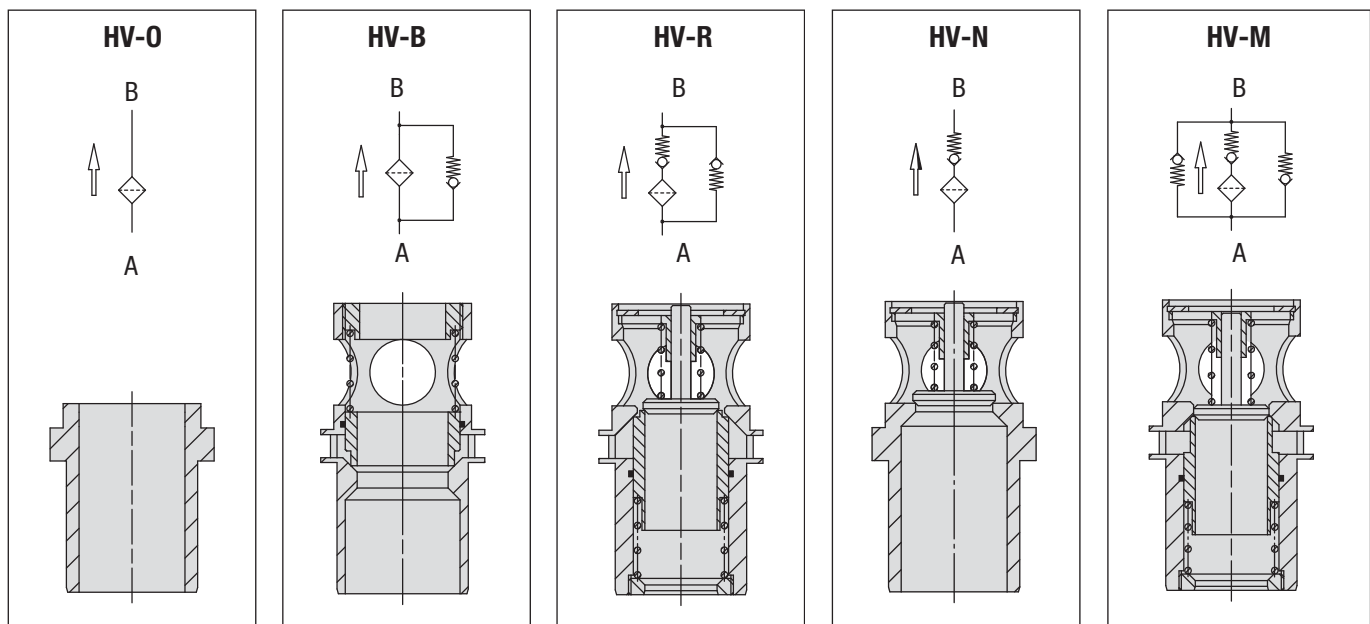

Flow characteristics of the valves see page C42

## Clogging Indicators

### Product Description

STAUFF Pressure Filters have a wide range of clogging indicators available. If no indicator is specified, the port is sealed by a plug (HI-0). The clogging indicators are actuated by the differential pressure ( $\Delta p$ ) across the element. The special piston design minimizes the effects of peak pressures in the system. An optional thermal lockout (thermo-stop) is available to prevent false indication under cold start conditions. Fluid temperature have to be at least +20 °C / +68 °F for the indicator to function. Special indicators with a temperature range down to -45 °C / -49 °F are available upon request.

### Technical Data

#### Materials

- Body: Stainless Steel
- Sealings: NBR (Buna-N®)  
FPM (Viton®)  
EPDM (Ethylene-Propylene-Diene-Monomer-Rubber)

#### Thread

- G 1/2

#### Differential Pressure

- 5<sub>-0,5</sub> bar / 72.5<sub>-7,25</sub> PSI pressure setting (other settings on request)

#### Electrical

- Plug according to DIN-EN 175301-803 A (DIN 43650-A). Screwed cable gland PG11, protection rating (DIN 40050) IP65, both NO and NC contacts are available in the switch, rated capacity: see chart below

The visual clogging indicators are available in the following configurations:

- Manual reset: The indicator continues to display the clogged signal even through the  $\Delta p$  may have fallen. Pressing the plastic cover down will reset the indicator.
- Automatic reset: The clogged signal will disappear when the  $\Delta p$  drops below the setting for the indicator.

Electrical and visual-electrical clogging indicators are only available with automatic reset.

### Order Code

**HI - P T 230 B 5,0B / X**

1 2 3 4 5 6 7

#### 1 Type

Clogging Indicator for Pressure Filters **HI**

#### 2 Indicator Type

Plug **O**  
 Visual, automatic reset **A**  
 Visual, manual reset **V**  
 Electrical **E**  
 Visual-electrical **P**

#### 3 Thermostop

Without thermostop **none**  
 With thermostop **T**

#### 4 Voltage (only for Code P)

24 V DC **24**  
 110 V AC **110**  
 230 V AC **230**

#### 5 Sealing Material

NBR (Buna-N®) **B**  
 FPM (Viton®) **V**  
 EPDM **E**

#### 6 Differential Pressure Setting

1,72 bar / 25 PSI **25P**  
 2,0 bar / 29 PSI **2,0B**  
 2,5 bar / 36.3 PSI (standard option) **2,5B**  
 3,0 bar / 43.5 PSI **3,0B**  
 5,0 bar / 72.5 PSI **5,0B**  
 7,0 bar / 101.5 PSI **7,0B**

#### 7 Design Code

Only for information **X**

### Dimensions

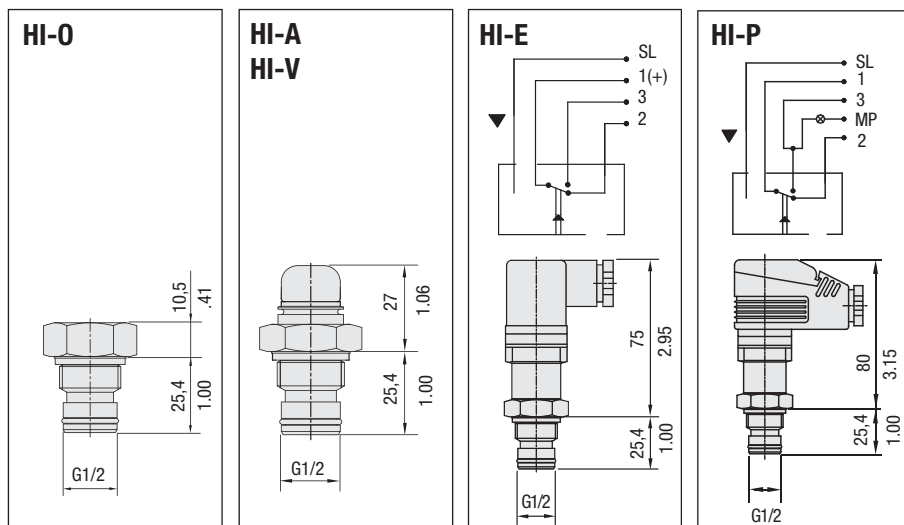

#### Rated Capacity HI-E and HI-P

Alternating current: 250 V AC 5 A

Direct current: see table below

Voltage V	Resistive Load A	Inductive Load A
24 V DC	8,00	7,00
110 V AC	0,50	0,20
230 V AC	0,25	0,10

High voltage peaks occur when inductive loads are switched off. Protective circuitry should be employed to reduce contact burnout.

## High and Medium Pressure Filters ■ Type SF / SF-TM / SF-SM / SFZ / SFA Filter Elements SE

**Product Description**

STAUFF SE series Replacement Filter Elements for SF / SF-TM / SF-SM / SFZ / SFA series filter housings are manufactured in the common filter materials such as Stainless Fibre, Stainless Mesh and Inorganic Glass Fibre. As standard, all Replacement Elements SE series have tin-plated steel parts for use with aggressive media such as water glycol, other materials available on request. All STAUFF Replacement Elements comply with quality specifications in accordance with international standards.

**Order Code**
**SE - 014 G 10 B / X**

1      2      3      4      5      6

**1 Type**

 Filter Element Series **SE**
**2 Group**

According to filter housing

**3 Filter Material**

Material	max. Δp*collapse	Micron ratings available	Code
Inorganic glass fibre	25 bar / 363 PSI	3, 5, 10, 20	<b>G</b>
Inorganic glass fibre	210 bar / 3045 PSI		<b>H</b>
Stainless fibre	210 bar / 3045 PSI		<b>A</b>
Stainless mesh	30 bar / 435 PSI	25, 50, 100, 200	<b>B, S</b>

Note: \* Collapse/burst resistance as per ISO 2941. Bold types identify preferred materials, other materials on request.

**4 Micron Rating**

3 µm	<b>03</b>
5 µm	<b>05</b>
10 µm	<b>10</b>
20 µm	<b>20</b>
25 µm	<b>25</b>
50 µm	<b>50</b>
100 µm	<b>100</b>
200 µm	<b>200</b>

Note: Other micron ratings on request.

**5 Sealing Material**

NBR (Buna-N®)	<b>B</b>
FPM (Viton®)	<b>V</b>
EPDM	<b>E</b>

Note: Other sealing materials on request.

**6 Design Code**

Only for information	<b>X</b>
----------------------	----------



High and Medium Pressure Filters - Type SF / SF-TM / SF-SM / SFA

The following characteristics are valid for mineral oils with a density of 0,85 kg/dm<sup>3</sup> and the kinematic viscosity of 30 mm<sup>2</sup>/s (30 cSt). The characteristics have been determined in accordance to ISO 3968. Multipass filter ratings have been obtained in accordance to ISO 16889. Consult STAUFF for details.

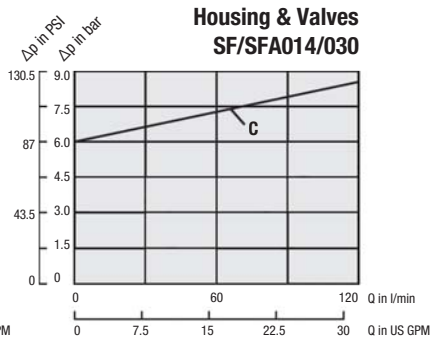
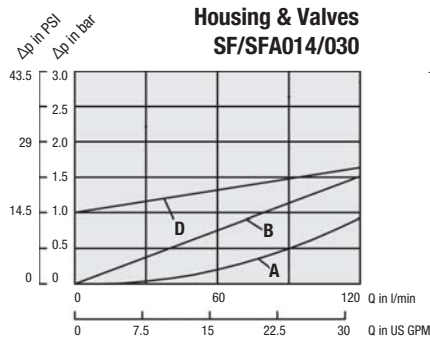

Valve Configuration	Flow direction	Curve
Housing with HV-O or HV-B	In → Out	A
HVM, HV-R, HV-N	In → Out	B
HV-M, HV-B ▪ Element 100% blocked Bypass only ▪ In reality always mixed mode	In → Out	C
HV-M, HV-R Reverse mode	Out → In	D

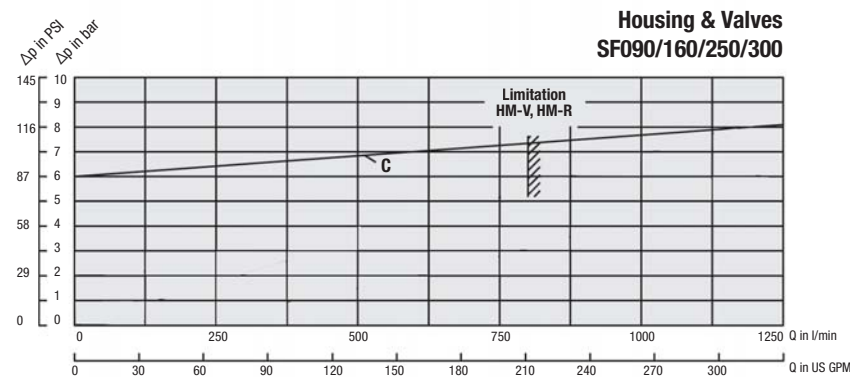
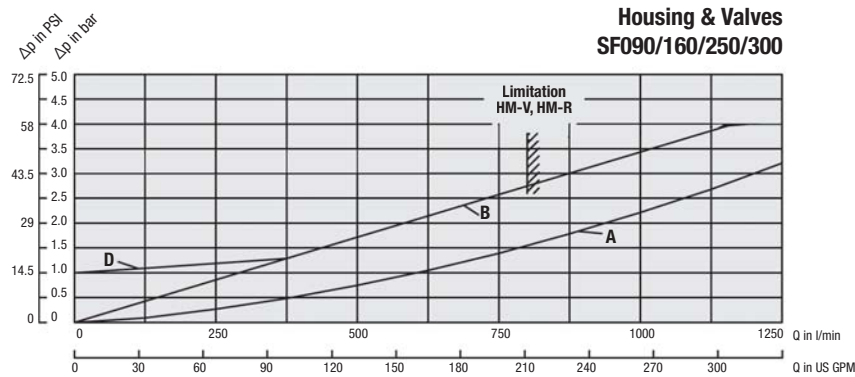
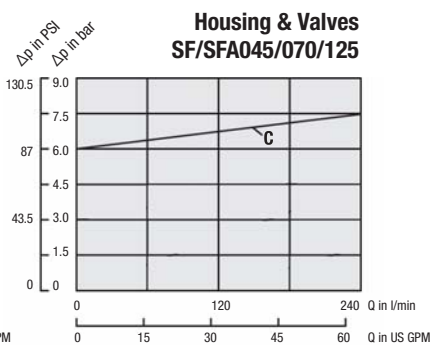
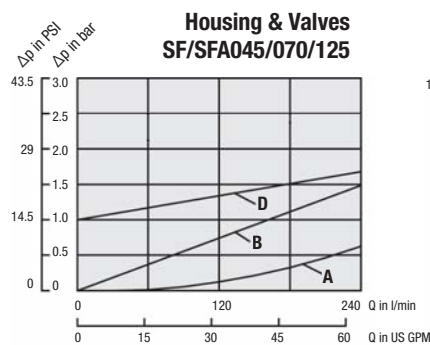

## High and Medium Pressure Filters ■ Type SF / SF-TM / SF-SM / SFA

The following characteristics are valid for mineral oils with a density of 0,85 kg/dm<sup>3</sup> and the kinematic viscosity of 30 mm<sup>2</sup>/s (30 cSt). The characteristics have been determined in accordance to ISO 3968. Multipass filter ratings have been obtained in accordance to ISO 16889. Consult STAUFF for details.

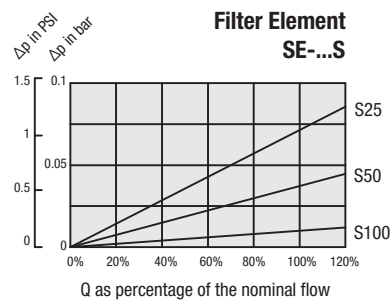
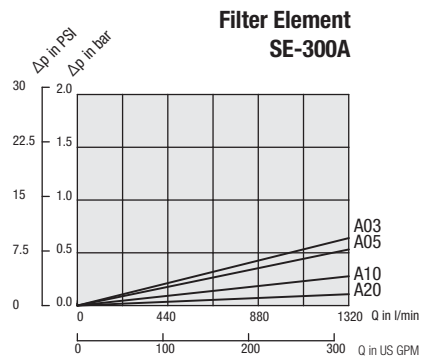
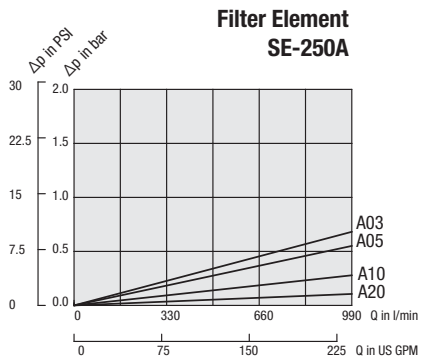
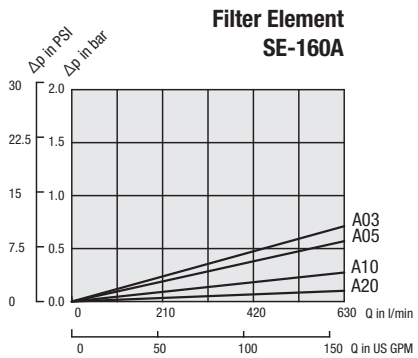
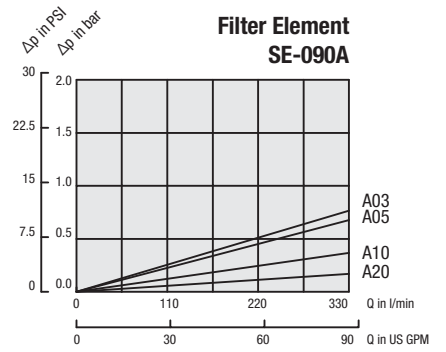
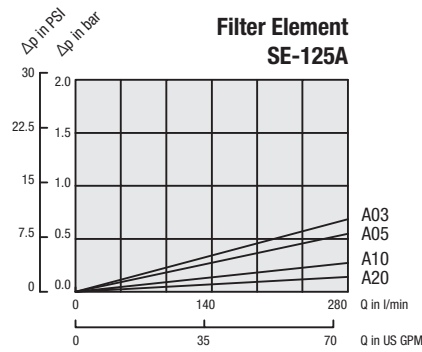
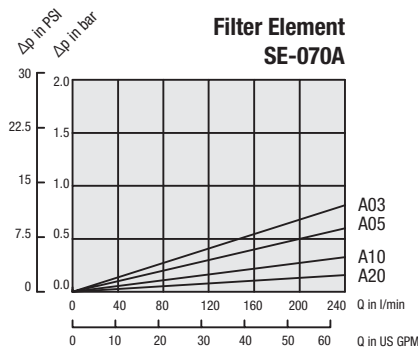
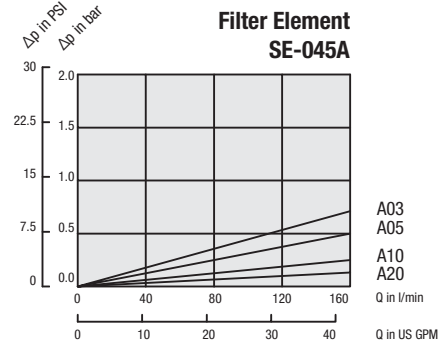
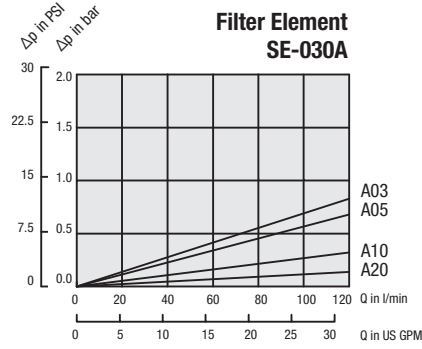
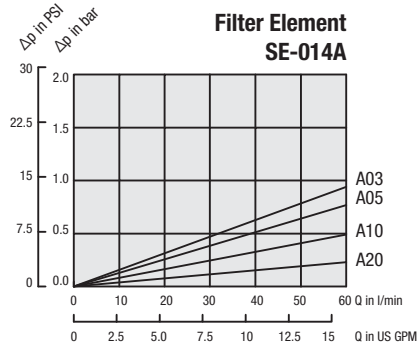

High and Medium Pressure Filters - Type SF / SF-TM / SF-SM / SFA

The following characteristics are valid for mineral oils with a density of 0,85 kg/dm<sup>3</sup> and the kinematic viscosity of 30 mm<sup>2</sup>/s (30 cst). The characteristics have been determined in accordance to ISO 3968. Multipass filter ratings have been obtained in accordance to ISO 16889. Consult STAUFF for details.

